

## CAST IRON Y STRAINER FLANGED PN 10/16



**Size :** DN 15 to DN 400  
**Ends :** Flanges GN10/16  
**Min Temperature :** - 10°C  
**Max Temperature :** + 120°C  
**Max Pressure :** 16 Bars up to DN 200 ( 10 bars over )  
**Specifications :** Removable stainless steel filter  
Bolted bonnet with draining cap

**Materials :** Cast iron body

# CAST IRON Y STRAINER FLANGED PN 10/16

**SPECIFICATIONS :**

- Removable stainless steel filter
- R.F. flanges GN16 up to DN200, GN10 over ( GN16 possible from DN 250 to 300 )
- Horizontal or vertical position with descendant fluid (respect the flow direction indicated by the arrow )
- Mesh 1,1mm up to DN 125, 1.5 mm from DN 150 to DN 300 , 3 mm for DN 350 and DN 400
- Bolted bonnet with draining cap threaded BSP

**USE :**

- For common fluids
- Min Temperature Ts : - 10°C
- Max Temperature Ts :+ 120°C
- Max Pressure Ps : 16 bars up to DN200 , 10 bars over

**HEAD LOSS GRAPH :**

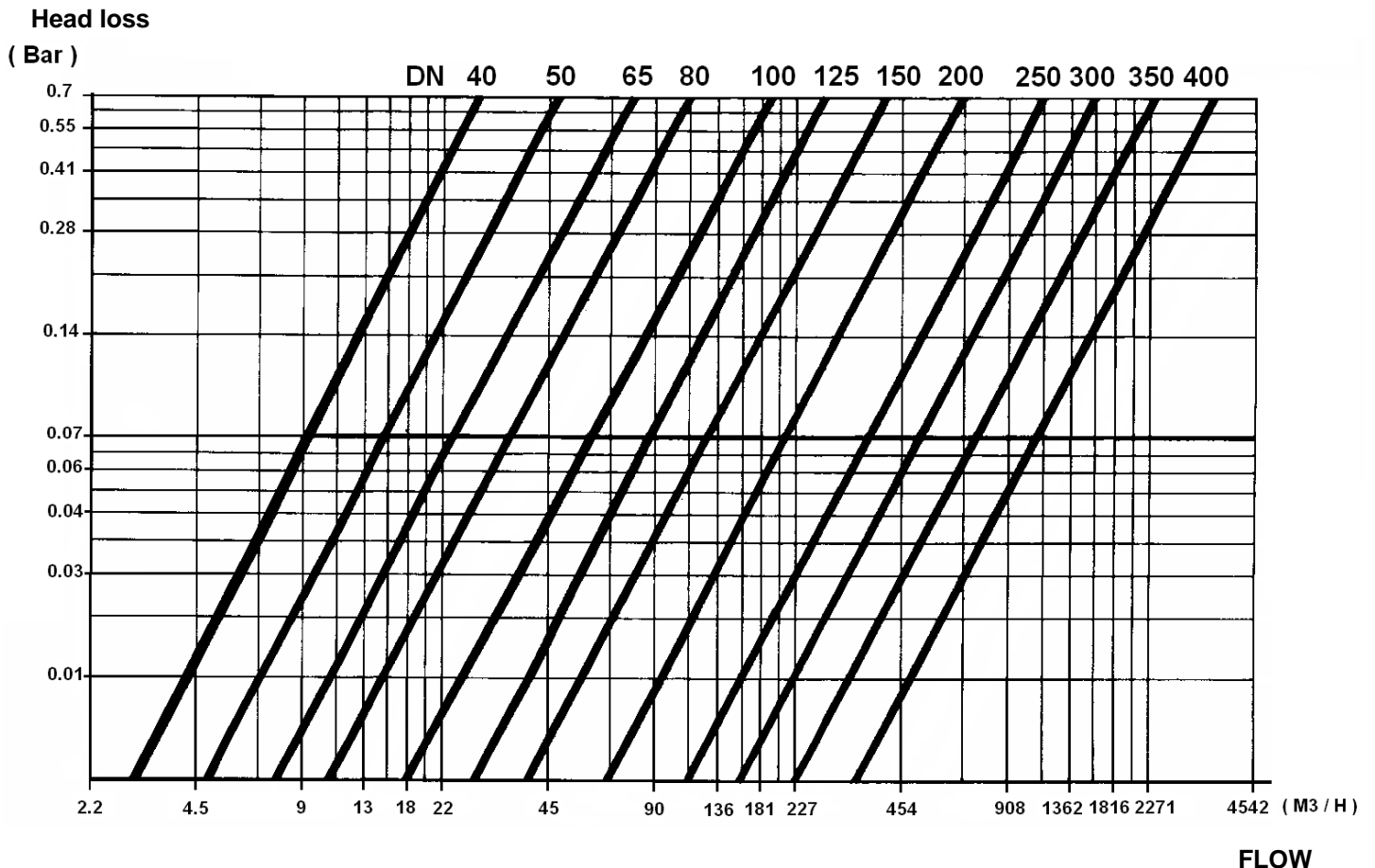

# CAST IRON Y STRAINER FLANGED PN 10/16

## RANGE :

- R.F. flanges GN10/16 from DN 15 to 150, GN16 for DN200, GN10 from DN250 to 400 ( GN16 possible for DN250 and 300 )

## MATERIALS :

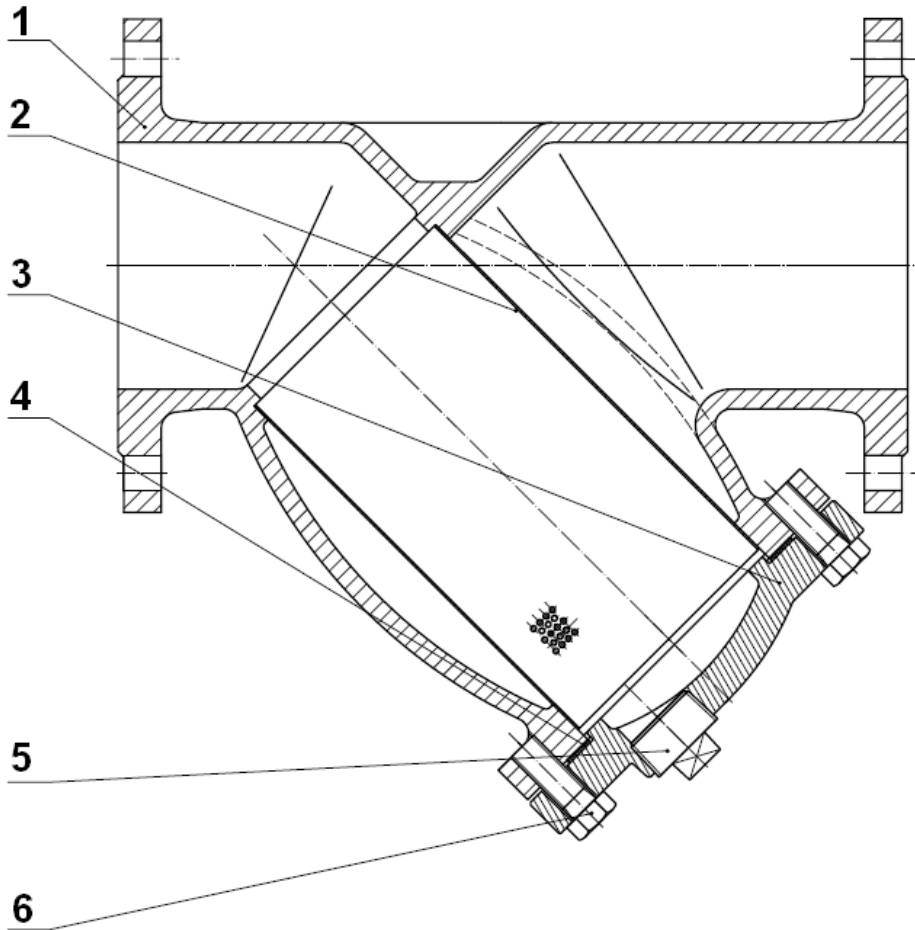

Item	Designation	Materials
1	Body	Cast iron EN GJL-250
2	Filter	SS 304
3	Bonnet	Cast iron EN GJL-250
4	Bonnet gasket	Graphite
5	Draining cap	Brass
6	Bonnet screw	Steel Rst 37-2

# CAST IRON Y STRAINER FLANGED PN 10/16

SIZE ( in mm ) :

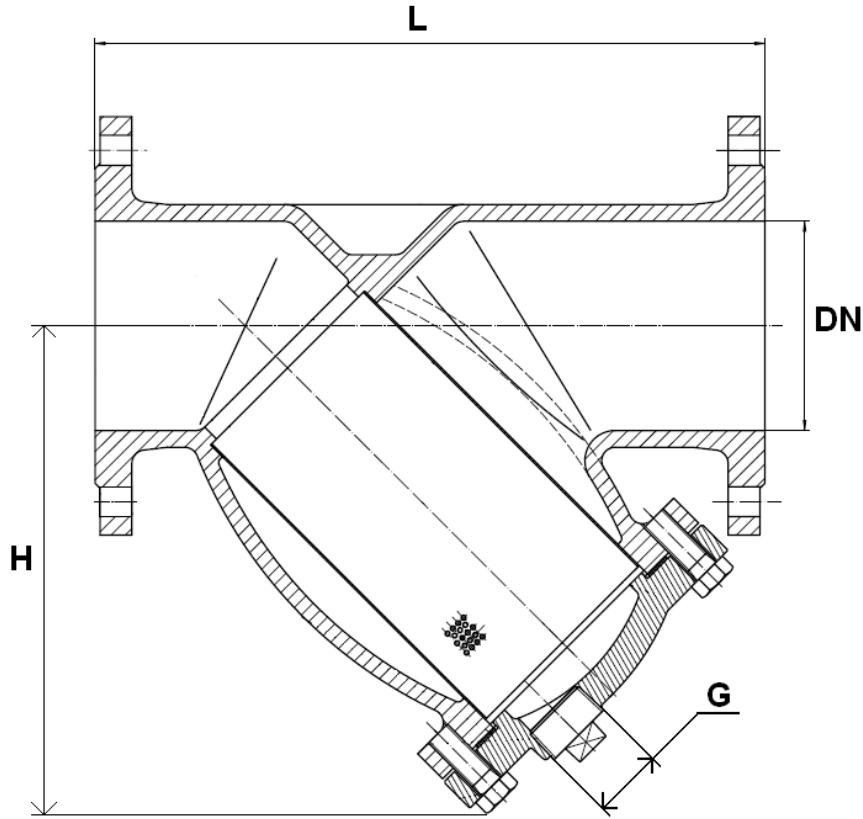

Filter size :

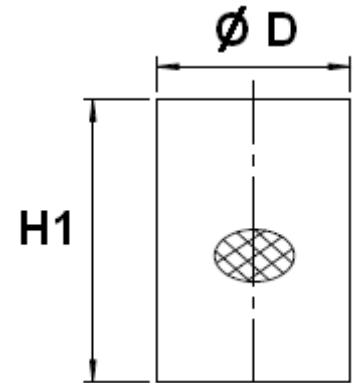

	DN	15	20	25	32	40	50	65	80	100	125	150	200	250	300	350	400	
<b>Ref.</b>  <b>220</b>	L	130	150	160	180	200	230	290	310	350	400	480	600	730	850	980	1100	
	H	55	78	84	120	131	135	165	186	226	267	305	358	516	568	648	759	
	G ( drain )	3/8"	3/8"	3/8"	3/8"	1/2"	1/2"	1/2"	3/4"	3/4"	3/4"	3/4"	1"	1/2"	1/2"	1/2"	1/2"	
	Ø D	16	22	28	35	41	51	67	79	99	129	156	209	250	300	353	403	
	H1	46	60	72	86	101	115	147	160	195	234	230	325	456	484	540	650	
	Mesh	1.1	1.1	1.1	1.1	1.1	1.1	1.1	1.1	1.1	1.1	1.1	1.5	1.5	1.5	1.5	3	3
	Weight (in Kg)	2.2	3	3.7	5.8	6.74	9.28	13.11	16.87	24.47	39.8	57	97	163.5	233.5	312	422	

# CAST IRON Y STRAINER FLANGED PN 10/16

## STANDARDS :

- Fabrication according to ISO 9001 : 2008
- DIRECTIVE 97/23/CE : Concerned by article 3, § 3
- Length according to DIN 3202 – NF 29354 , EN 558-1 serie 1
- R.F. flanges according to EN 1092-1 PN10/16

## INSTALLATION POSITIONS :

Vertical position ( descendand fluid )



Horizontal position



**ADVICE :** Our opinion and our advice are not guaranteed and SFERACO shall not be liable for the consequences of damages.  
The customer must check the right choice of the products with the real service conditions.

# CAST IRON Y STRAINER FLANGED PN 10/16

## INSTALLATION INSTRUCTIONS

### GENERAL GUIDELINES :

- Ensure that the strainers to be used are appropriate for the conditions of the installation (type of fluid, pressure and temperature).
- Be sure to have enough valves to be able to isolate the sections of piping as well as the appropriate equipment for maintenance and repair.
- Ensure that the strainers to be installed are of correct strength to be able to support the capacity of their usage.
- **Installation of all circuits should ensure that their function can be automatically tested on a regular basis (at least two times a year).**

### INSTALLATION INSTRUCTIONS :

- **Before installing the strainers, clean and remove any objects from the pipes** (in particular bits of sealing and metal) which could obstruct and block the strainers.
- **Ensure that both connecting pipes either side of the strainer (upstream and downstream) are aligned (if they're not, the strainer may not work correctly).**
- **Make sure that the two sections of the pipe (upstream and downstream) match, the strainer unit will not absorb any gaps. Any distortions in the pipes may affect the tightness of the connection, the working of the strainer and can even cause a rupture.** To be sure, place the kit in position to ensure the assembling will work.
- Make sure flanges are cleaned.
- **If sections of piping do not have their final support in place, they should be temporarily fixed. This is to avoid unnecessary strain on the strainer.**
- Tighten the bolts in cross.
- The pressurisation must be increased gradually.
  - So that the maintenance operations could be easily done, place a stop valve before and after the strainer. Thereby, the strainer could be isolated. During this operation, ensure to have a new bonnet gasket to avoid a leakage during the restarting.
- **Fluids in the strainer must not contain solid objects ( it could damaged the seat ).**