

REF. 7143

DRY CLEANED 2 PIECES BALL VALVE FOR OXYGEN



TÜVRheinland[®]
ISO 9001 : 2015

TÜVRheinland[®]
PED/2014/68/UE

CE



Certificate 3.1

Size : DN 1/4" to 2"
Ends : Female BSP
Min Temperature : - 20°C
Max Temperature : + 200°C
Max Pressure : 63 Bars
Specifications : For oxygen
PTFE filled with glass seat
Anti blow-out stem
Atex
Dry cleaned for oxygen

Materials : Stainless steel EN 1.4408

DRY CLEANED 2 PIECES BALL VALVE FOR OXYGEN**SPECIFICATIONS :**

- Full bore
- Anti blow-out stem
- PTFE filled with glass seat
- Locking handle
- Atex
- Double antistatic device
- 2 pieces type
- Solid ball
- Dry cleaned for oxygen

USE :

- For oxygen
- Min and max Temperatures Ts : -20°C to + 200°C
- Max Pressure Ps : 63 bars (see graph)

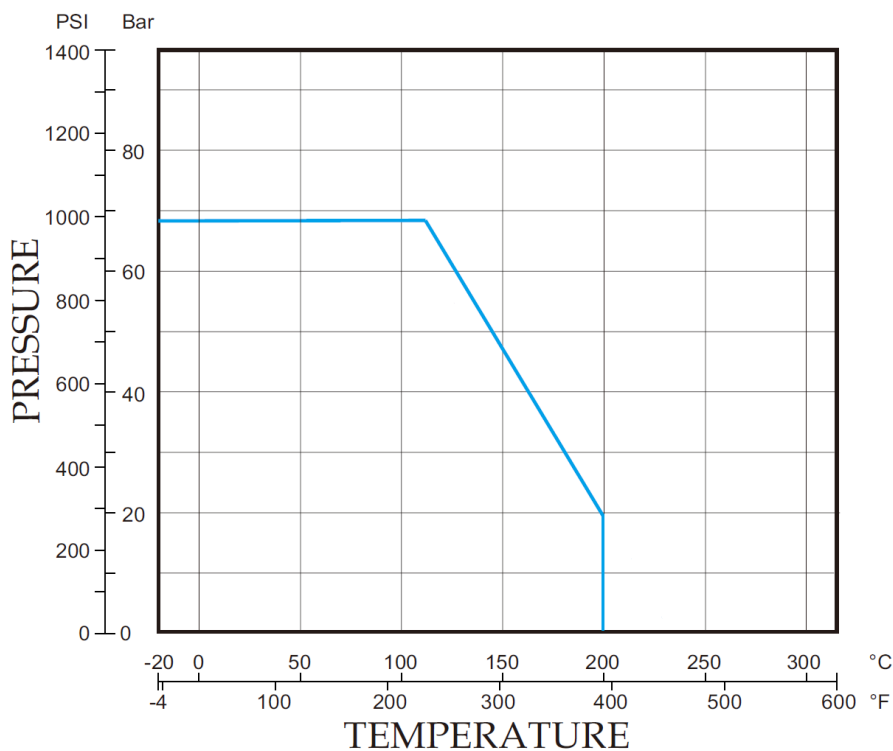
PRESSURE / TEMPERATURE GRAPH (STEAM EXCLUDED) :**RANGE :**

- Dry cleaned stainless steel ball valve for oxygen **Ref. 7143** from DN 1/4" to DN 2"

ENDS :

- Female / female threaded BSP cylindrical ends

DRY CLEANED 2 PIECES BALL VALVE FOR OXYGEN

MATERIALS :

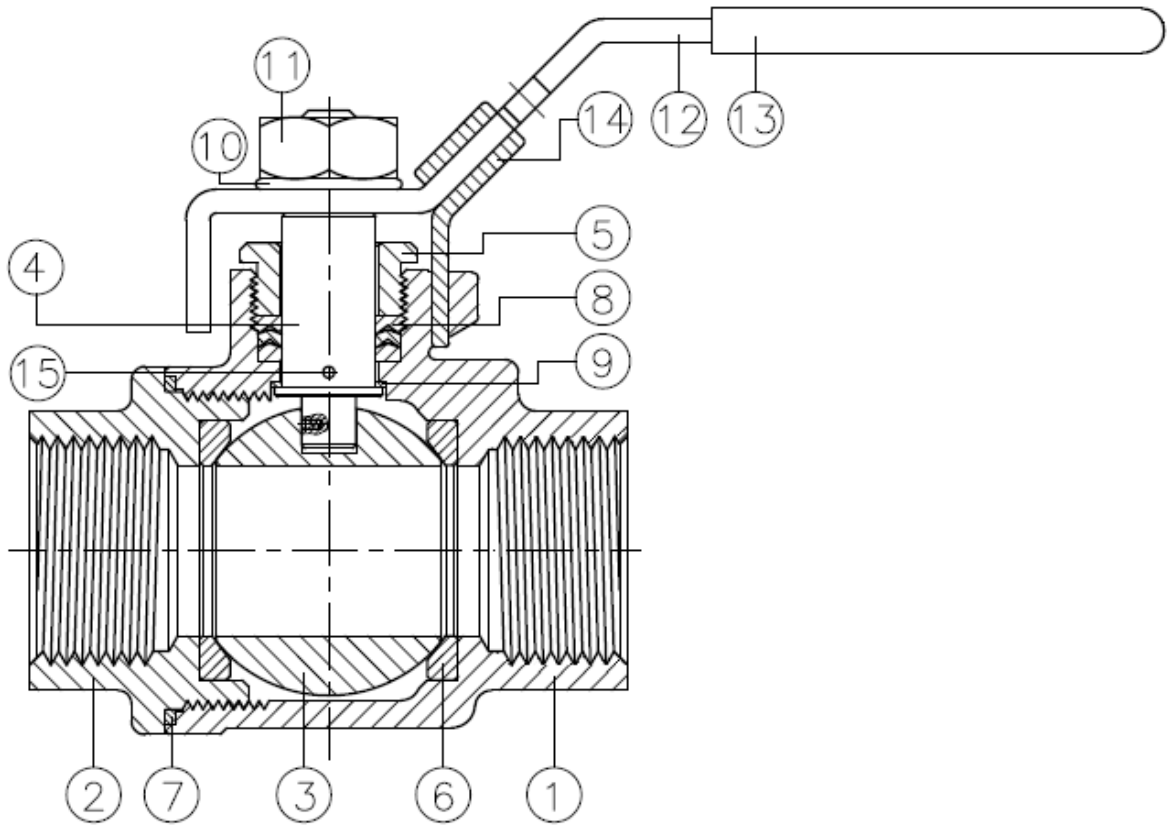

Item	Designation	Materials
1	Body	EN 1.4408
2	Ends	
3	Ball	
4	Stem	ASTM A276-316
5	Packing nut	AISI 304
6	Seat	PTFE filled with 15% glass fiber
7	Body gasket	PTFE
8	Packing	
9	Gasket	
10	Washer	AISI 304
11	Handle nut	
12	Handle	
13	Handle cover	PVC
14	Locking device	AISI 304
15	Antistatic device	AISI 316

REF. 7143

DRY CLEANED 2 PIECES BALL VALVE FOR OXYGEN

SIZE (in mm) :

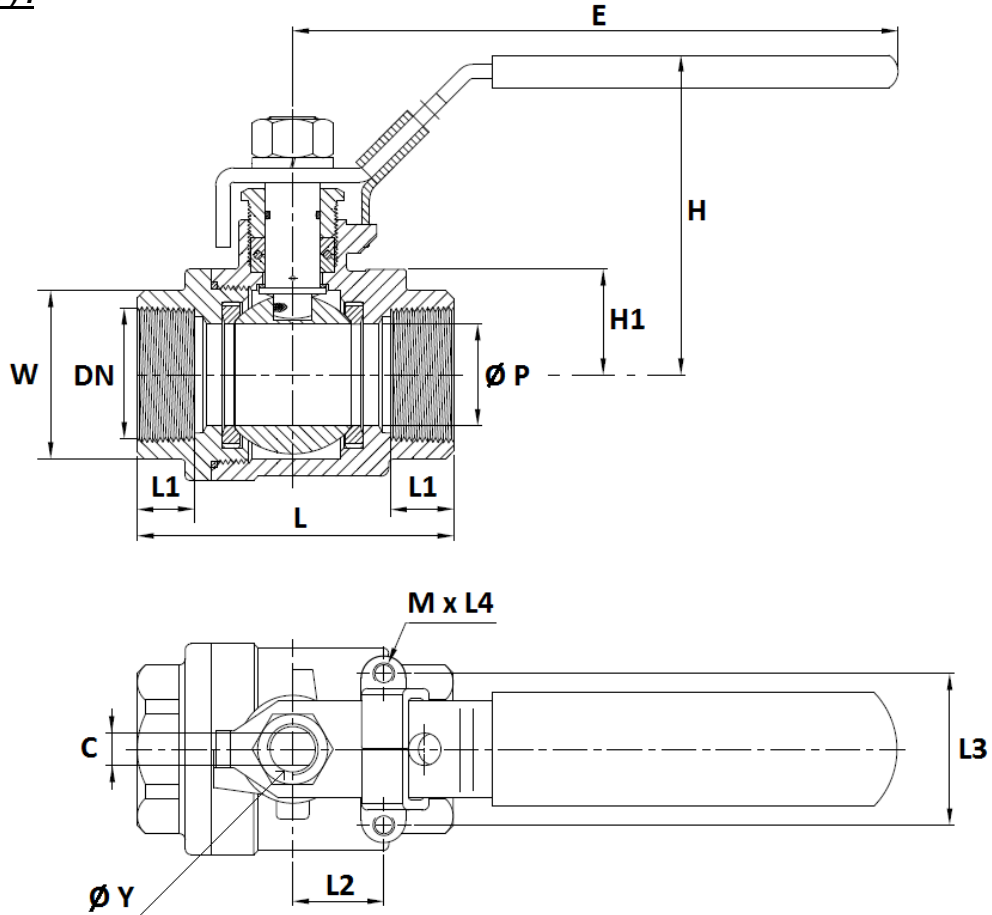

DN	1/4"	3/8"	1/2"	3/4"	1"	1"1/4"	1"1/2"	2"
Ø P	11.6	12.5	15	20	25	32	38	50
L	50.8	50.8	58	65.6	78.7	90	105	124
L1	10	9	13	13	17	18	20	24
L2	12.7	12.7	12.7	12.7	22.4	22.4	23.2	23.2
L3	28.5	28.5	28.5	28.5	35	35	38.1	38.1
M x L4	M5 x 5.5			M5 x 6	M5 x 6.5	M6 x 5.5	M6 x 6	
E	100	100	100	125	149	149	190	190
H	58.5	58.5	58.5	63.5	78	83	102	108
H1	15.8	15.8	15.8	21.3	23.8	30.5	35.5	44.3
C	5	5	5	6.5	8	8	10	10
Ø Y	9.5 (3/8"-24UNF)			11.1 (7/16"-20UNF)			12.7 (1/2"-20UNF)	
W (on flat)	19	23	26	32	38	49	54	67
Weight (Kg)	0.2	0.2	0.3	0.5	0.8	1.1	1.8	2.7

REF. 7143

DRY CLEANED 2 PIECES BALL VALVE FOR OXYGEN

FLOW COEFFICIENT Kvs (M3 / h) :

DN	1/4"	3/8"	1/2"	3/4"	1"	1"1/4	1"1/2	2"
Kvs (m3/h)	19	22	34	62	98	170	247	427

TORQUE VALUES (in Nm without safety coefficient) :

DN	1/4"	3/8"	1/2"	3/4"	1"	1"1/4	1"1/2	2"
Torque (Nm)	3.5	4	5.5	7.5	11	15	20	40

STANDARDS :

- Fabrication according to ISO 9001 : 2015
- DIRECTIVE 2014/68/EU : CE N° 0035
Risk category III Module H
- Certificate 3.1 on request
- Pressure tests according to API 598, table 6
- Female cylindrical BSP threaded ends according to ISO 7/1 Rp
- ATEX Group II Category 2 G/2D Zone 1 & 21 Zone 2 & 22 (optional marking)

ADVICE : Our opinion and our advice are not guaranteed and SFERACO shall not be liable for the consequences of damages.
The customer must check the right choice of the products with the real service conditions.

DRY CLEANED 2 PIECES BALL VALVE FOR OXYGEN**INSTALLATION AND MAINTENANCE****BEFORE INSTALLATION :**

Pipe-line must be cleaned and free from residual of weldings, rubbish, shaving and every kind of extraneous materials.

Pipe-line must be perfectly aligned and their support properly dimensioned so that there's no external constraint.

Please use the right product according to the services conditions to seal the valve.

Use the right bolt tightening so that the ends won't be damaged.



- For an installation in ATEX area, check the conductivity between the valve, the upstream pipe and the downstream pipe and make sure the pipe is connected to the earth.

CLEANING AND TESTS

Keep closed the valves during the cleaning operation so that there's no impurities between the ball and the body.

Tests under pressure must be done with a cleaned pipe-line.

Open partially the valve for tests. Pressure test do not exceed the valve specifications according to API 598.

MAINTENANCE

It's recommended to operate the valve twice (open and close) 1 to 2 times per year.

When intervention on the valve, be sure there's no pressure in the pipe-line, there's no fluid in it, and that it is isolated.

The temperature must be low enough to operate without risks.

If there's a corrosive fluid, inert installation before intervention.

When the valve is under pressure :

If there's a leakage at the packing, tighten it slightly so that the leakage disappears.