

3 PIECES S.S. BALL VALVE FLANGED PN 40 PERFORMANCE RANGE

Certificate 3.1

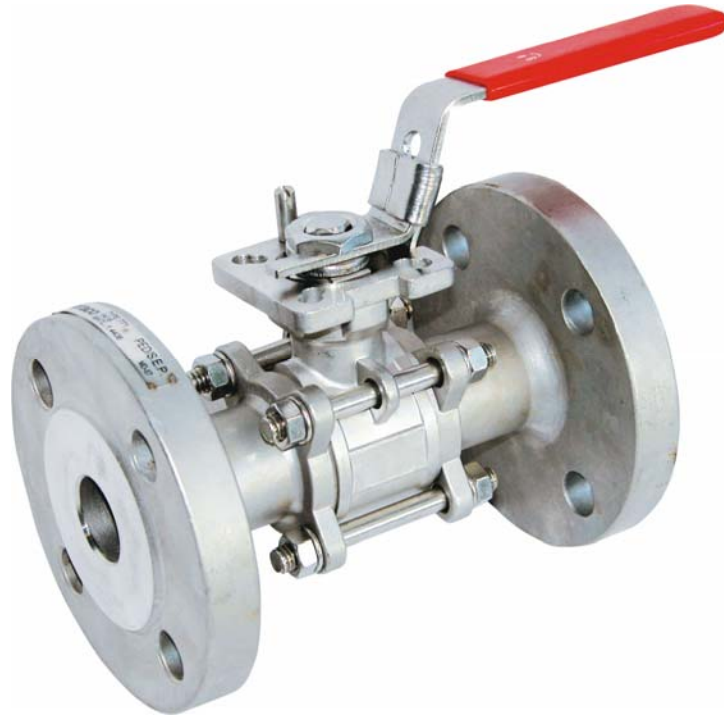

Lloyd's
Register

PED 97/23/CE



BUREAU
VERITAS
TA LUFT



Size : DN 15 to 100 mm
Ends : Flanges R.F. PN40
Min Temperature : - 30°C
Max Temperature : + 220°C
Max Pressure : 40 Bars
Specifications : ISO 5211 mounting pad
PTFE filled with stainless steel seat
Anti blow-out stem
Atex

Materials : Stainless steel ASTM A351 CF8M

3 PIECES S.S. BALL VALVE FLANGED PN 40 PERFORMANCE RANGE

SPECIFICATIONS :

- Full bore
- Anti blow-out stem
- Special gland pack with elastic washer
- Antistatic device from DN15 to 32, double antistatic device (ball between body-stem and ball-stem) from DN40 to 100
- PTFE filled with stainless steel seat
- Locking device
- Blue handle cover possible
- ISO 5211 mounting pad
- 3 pieces type

USE :

- Chemical and pharmaceutical industries, petrochemical industries, hydraulic installation, compressed air
- Steam : 18 bars maximum
- Vacuum : 10^{-2} torr
- Min and Max Temperature Ts : -30°C to + 220°C
- Max Pressure Ps : 40 bars (see graph)

RANGE :

- 3 pieces stainless steel ball valve **Ref. 711** from DN 15 to DN 100
- Blue handle cover **Ref. 9830432-9830436** from DN 15 to DN 100

ENDS :

- Flanges R.F. PN40

3 PIECES S.S. BALL VALVE FLANGED PN 40 PERFORMANCE RANGE

PRESSURE / TEMPERATURE GRAPH :

Pressure (Bar)

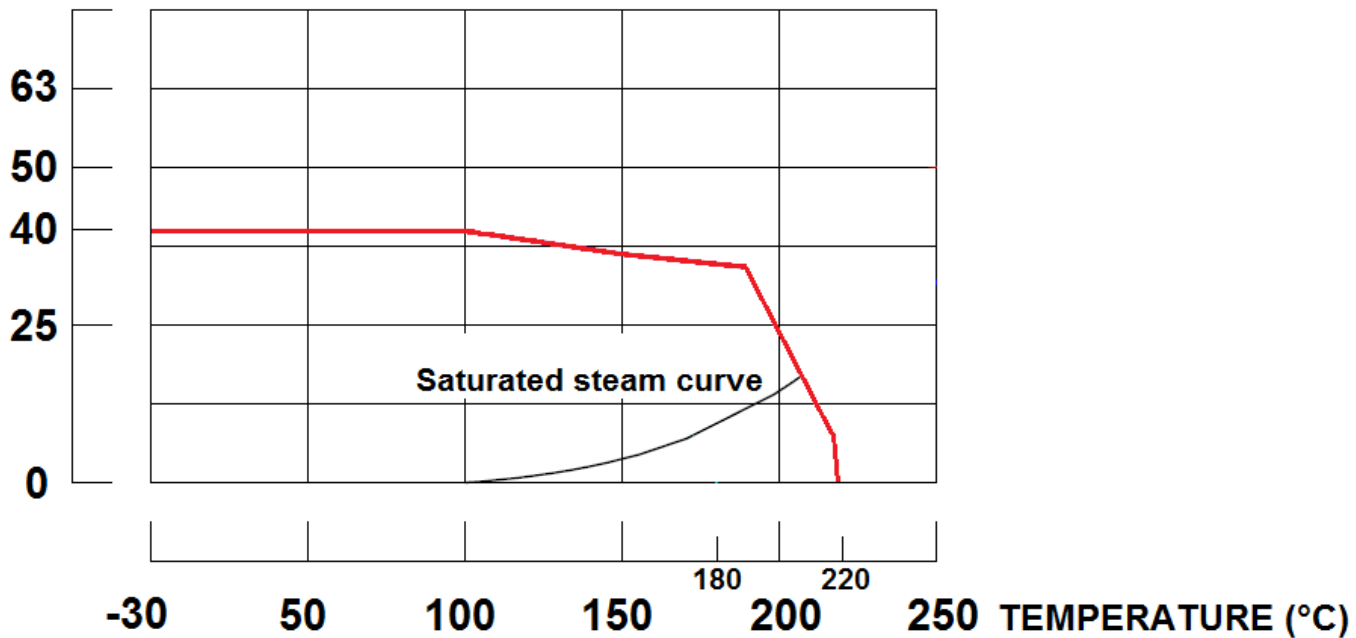

3 PIECES S.S. BALL VALVE FLANGED PN 40 PERFORMANCE RANGE

MATERIALS :

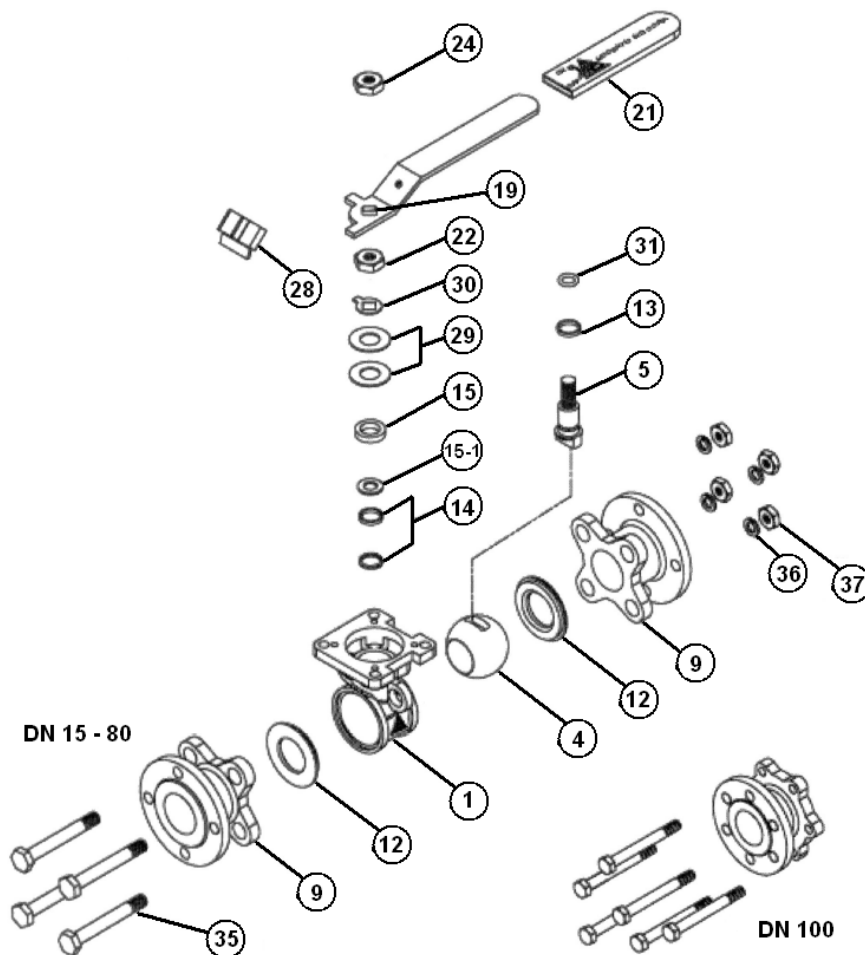

Item	Designation	Materials
1	Body	ASTM A351 CF8M
4	Ball	
5	Stem	AISI 316
9	Ends	ASTM A351 CF8M
12*	Seat	PTFE with 50% AISI 316
13*	Thrust washer	PTFE with 25% grafoil
14*	Stem packing	PTFE with 25% grafoil
15-1*	Packing Follower	PTFE with 15% grafoil
15	Gland bush	AISI 304
19	Handle	
21	Handle cover	Plastic
22	Stem nut	AISI 304
24	Handle nut	
28	Locking device	
29	Elastic washer	AISI 301
30	Tab washer	AISI 304
31*	O-ring	FKM
35	Body bolt	AISI 304
36	Bolt washer	
37	Bolt nut	

(* : Included in gaskets kit)

3 PIECES S.S. BALL VALVE FLANGED PN 40 PERFORMANCE RANGE

SIZE (in mm) :

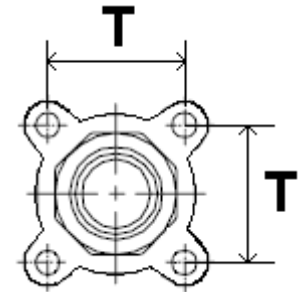
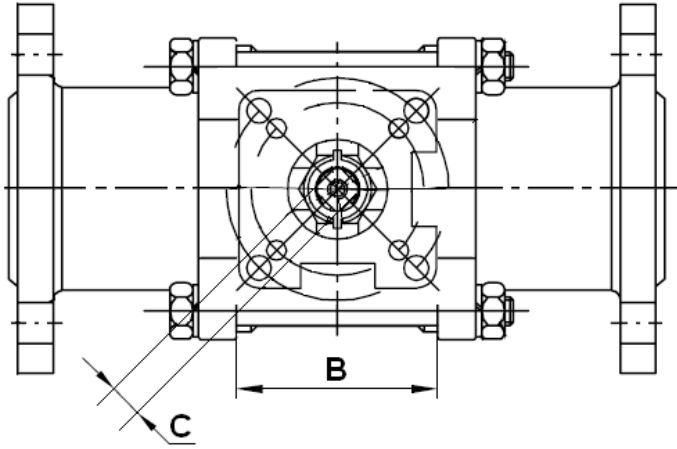

DN 15 – 80

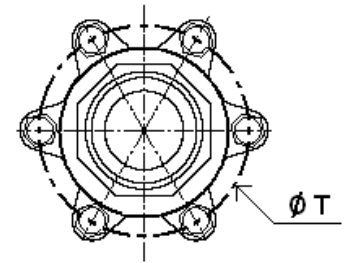
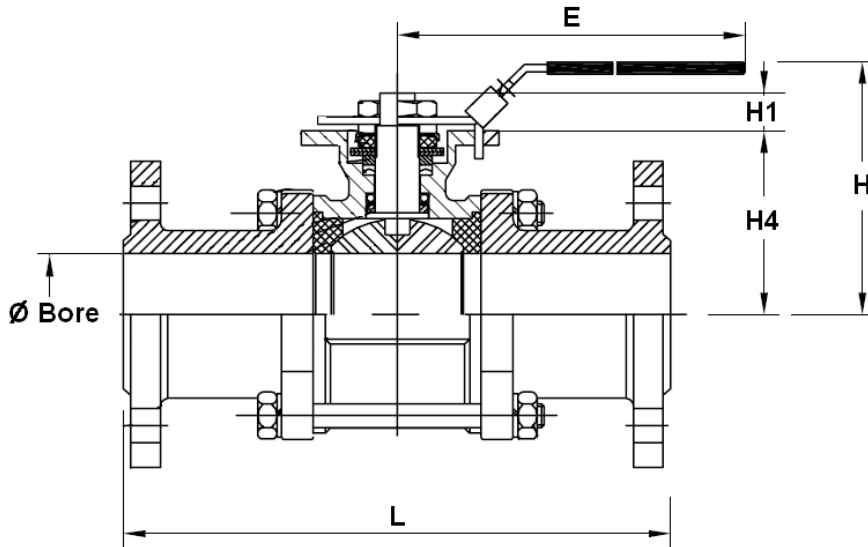

DN 100

Ref.	DN	15	20	25	32	40	50	65	80	100
711	Ø Bore	15	20	25	32	38	50	65	80	100
	L	130	150	160	180	200	230	290	310	350
	B	22.5	27.5	34	42.5	52	63.5	85.5	102	129
	E	112	112	136	185	197.9	197.9	264	264	325
	H	73	80.8	90.5	98.7	115.3	124	155	208.5	216.7
	H1	8.5	8.5	11.4	11.4	14	13.7	18	18	23
	H4	37	45	53.5	59	74.8	83.5	108.8	118.3	153.8
	C	9	9	9	9	14	14	17	17	17
	T	31	35	41	49	59	71	91	107	195
	Weight (Kg)	2.04	2.9	3.66	5.4	6.76	9.75	15.36	21.33	36.70

Stem size :

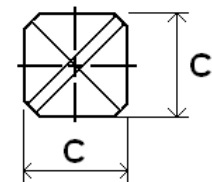

3 PIECES S.S. BALL VALVE FLANGED PN 40 PERFORMANCE RANGE

ISO MOUNTING PAD AND STEM SIZE (in mm) :

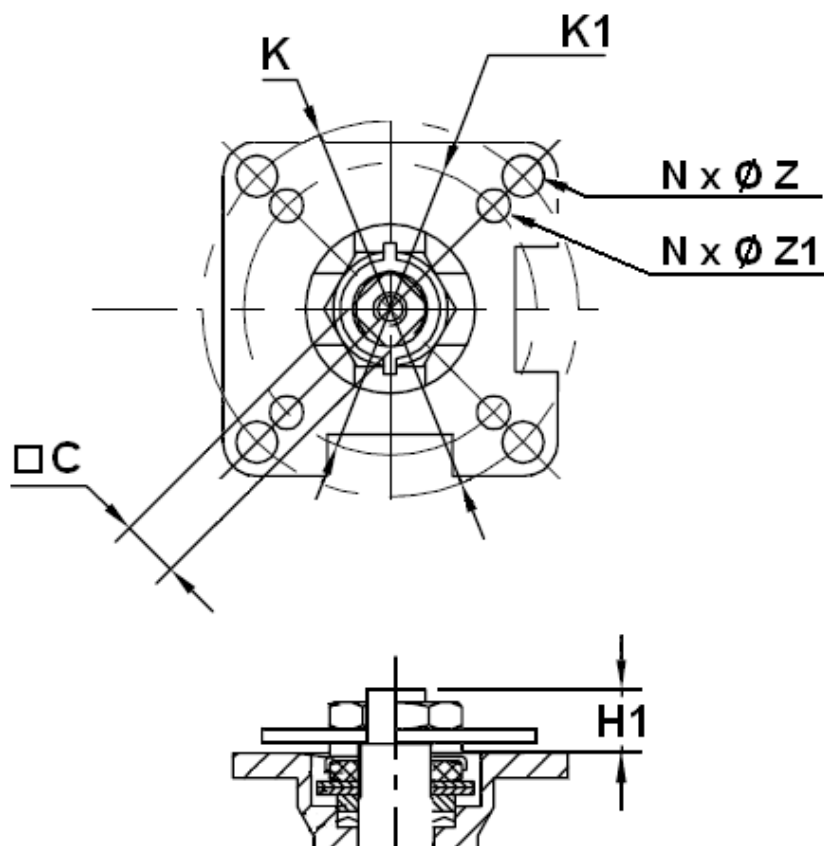

Ref.	DN	15	20	25	32	40	50	65	80	100
711	C	9	9	9	9	14	14	17	17	17
	H1	8.5	8.5	11.4	11.4	14	13.7	18	18	23
	Ø K	50	50	50	50	70	70	102	102	102
	ISO	F05	F05	F05	F05	F07	F07	F10	F10	F10
	N x Ø Z	4 x 7	4 x 7	4 x 7	4 x 7	4 x 9	4 x 9	4 x 11	4 x 11	4 x 11
	Ø K1	36	36	36	36	50	50	70	70	70
	ISO 1	F03	F03	F03	F03	F05	F05	F07	F07	F07
	N x Ø Z1	4 x 6	4 x 6	4 x 6	4 x 6	4 x 7	4 x 7	4 x 9	4 x 9	4 x 9

3 PIECES S.S. BALL VALVE FLANGED PN 40 PERFORMANCE RANGE

FLANGES SIZE (in mm) :

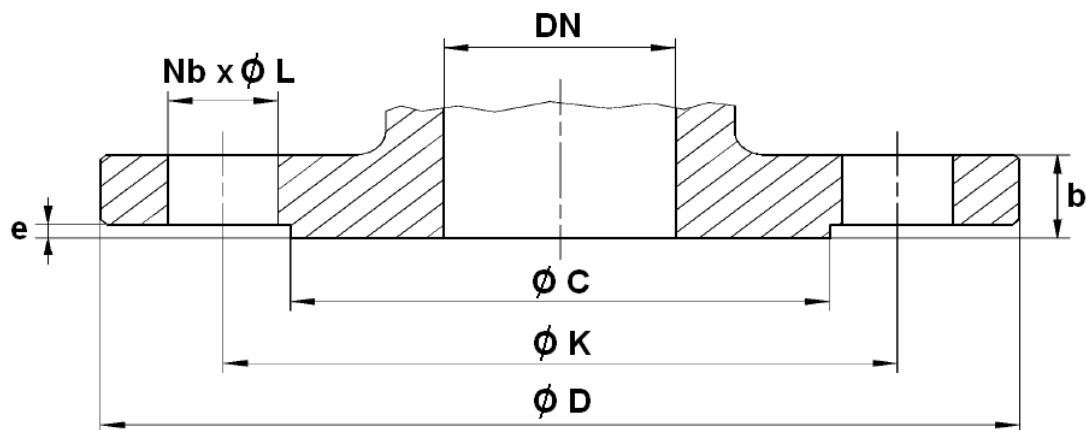

DN	15	20	25	32	40	50	65	80	100
Ø C	45	58	68	78	88	102	122	138	162
Ø D	95	105	115	140	150	165	185	200	235
Ø K	65	75	85	100	110	125	145	160	190
Nb x Ø L	4 x 14	4 x 14	4 x 14	4 x 18	4 x 18	4 x 18	8 x 18	8 x 18	8 x 22
b	16	18	18	18	18	20	22	24	24
e	2	2	2	2	3	3	3	3	3

3 PIECES S.S. BALL VALVE FLANGED PN 40 PERFORMANCE RANGE

TORQUE VALUES (in Nm without safety coefficient) :

DN	15	20	25	32	40	50	65	80	100
Torque (Nm)	7.6	14.5	21	25	35	60	80	88	190

BOLT TIGHTENING TABLE (in Nm):

DN	15	20	25	32	40	50	65	80	100
Torque (Nm)	6.9	9.8	9.8	11.8	15.7	20.6	54.9	73.5	94.1

FLOW COEFFICIENT Kvs (M3 / h):

DN	15	20	25	32	40	50	65	80	100
Kvs (m3/h)	31.3	57.9	94.3	157.9	227.9	414.8	720.2	1091	1754

STANDARDS :

- Fabrication according to ISO 9001 : 2008
- DIRECTIVE 97/23/CE : CE N° 0038
Risk Category III Module H
- Certificate 3.1 on request
- Construction according to EN 12516
- Pressure tests according to EN 12266-1, rate A
- Flanges according to EN 1092-1 PN40
- ISO 5211 mounting pad
- Length according to EN 558 series 1 (NF 29355 DIN 3202 F1)
- ATEX Group II Category 2 G/2D Zone 1 & 21 Zone 2 & 22 (optional marking) according directive 2014/34/EU
- Tightness on stem according to TA LUFT VDI 2440/3.3.1.3

3 PIECES S.S. BALL VALVE FLANGED PN 40 PERFORMANCE RANGE

INSTALLATION AND MAINTENANCE

BEFORE INSTALLATION :

Pipe-line must be cleaned and free from residual of weldings,rubbish,shaving and every kind of extraneous materials.
Pipe-line must be perfectly aligned and their support properly dimensioned so that there's no external constraint.

To tighten the ends,use the appropriate tool.
Use the right bolt tightening so that the ends won't be damaged.

INSTALLATION OF THE CENTRAL PART

During the installation of the central part , tighten bolts according to the table below.Tighten bolts in cross.

BOLT TIGHTENING TABLE (in Nm) :

DN	15	20	25	32	40	50	65	80	100
Torque (Nm)	6.9	9.8	9.8	11.8	15.7	20.6	54.9	73.5	94.1

CLEANING AND TESTS

Keep closed the valves during the cleaning operation so that there's no impurities between the ball and the body.

Tests under pressure must be done with a cleaned pipe-line.

Open partially the valve for tests. Pressure test do not exceed the valve specifications according to EN 12266-1.

MAITENANCE

It's recommended to operate the valve twice (open and close) 1 to 2 times per year.

When intervention on the valve, be sure there's no pressure in the pipe-line, there's no fluid in it,and that it is isolated.
The temperature must be low enough to operate without risks.
If there's a corrosive fluid,inert installation before intervention.

When the valve is under pressure :
If there's a leakage between the body and the ends, tighten bolts according to the above table

If there's a leakage at the packing, tighten it slightly so that the leakage disappears.

MAINTENANCE OPERATION IN WORKSHOP

REPLACEMENT OF SEAT GASKETS AND PACKING.

The central part must be removed.

Turn the ball at 45° and removed the seat gaskets.

Operate the valve in closed position to removed the ball.Verify the surface of the ball has no impacts and no scores.

If there are important scores or impatcs,replace the ball.

Clean inside the body valve and remove the impurities.

To replace the packing,remove the handle,unscrew the gland nut, extract the stem by the inside of the valve.

Clean the paking seat.

Reassemble thrust washer on stem, introduce stem by the inside of the valve, reassemble packing with packing nut,reassemble hand washer,hand nut and the handle.

Turn stem in closed position and insert the ball.

Then turn the ball in opened position and reassemble the seat.

Place the valve on the installation,tighten bolts according to the above table.

Then proceed to the tests in the same way that the first installation.