

BRASS BALL VALVE NF FOR GAS AIRGAS TYPE



SINCERT



Size : DN 1/2" to 2"
Ends : Female / Female BSP
Min Temperature : - 5°C
Max Temperature : + 60°C
Max Pressure : 5 Bars
Specifications : Anti blow-out stem
Double o ring FKM on stem
Full bore

Materials : Brass

BRASS BALL VALVE NF FOR GAS AIRGAS TYPE

SPECIFICATIONS :

- Heavy type
- For steel pipe (possible for copper pipe but only with ISO 7 male conical fittings, no gasket fitting with tightness inside the worm thread)
- Full bore
- Anti blow-out stem
- Solid ball
- Double o ring FKM on stem
- Flat yellow color steel handle

USE :

- Gas MOP 5 class
- Natural Gas : obtained from petroleum (methane) and mix of propane / air
- Town gas
- Liquid gas : Propane and mix of propane / butane
- Installation in building XPE 29141
- Min Temperature Ts : - 5 °C
- Max Temperature Ts : + 60°C
- Max Pressure PN : 5 bars

HEAD LOSS GRAPH :

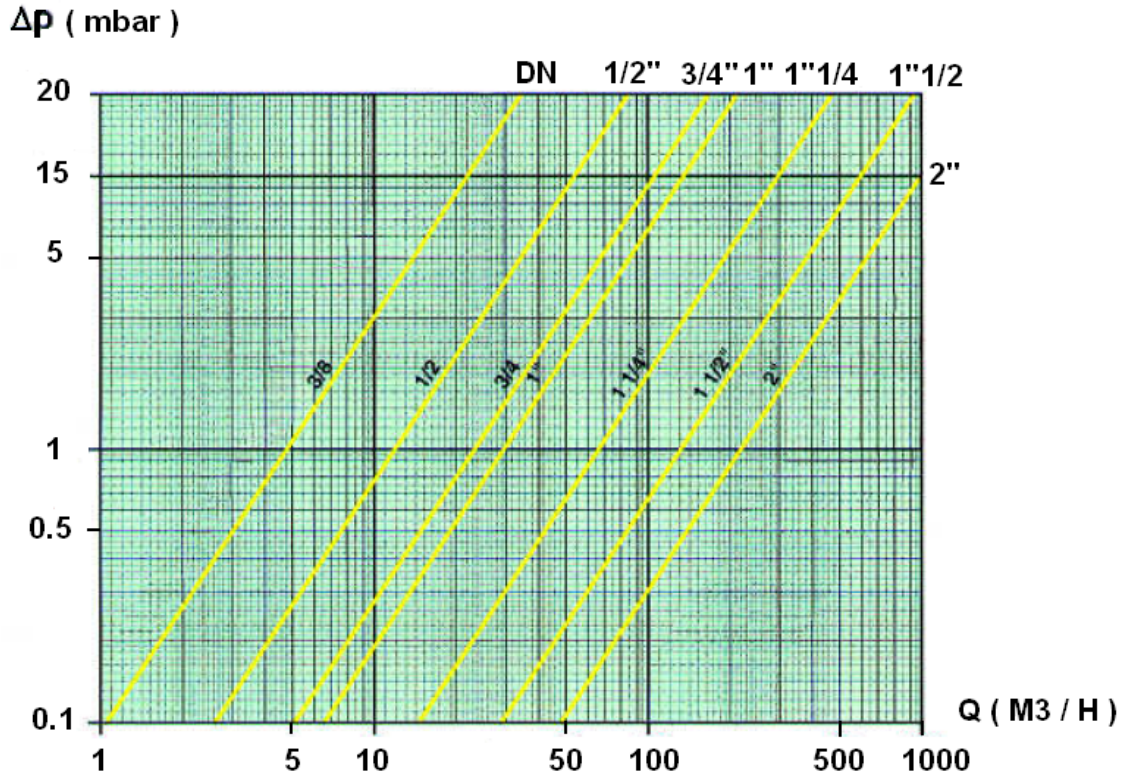

RANGE :

- Female / Female BSP threaded valve for gas with flat yellow steel handle **Ref. 620** from DN 1/2" to 2"

BRASS BALL VALVE NF FOR GAS AIRGAS TYPE

MATERIALS :

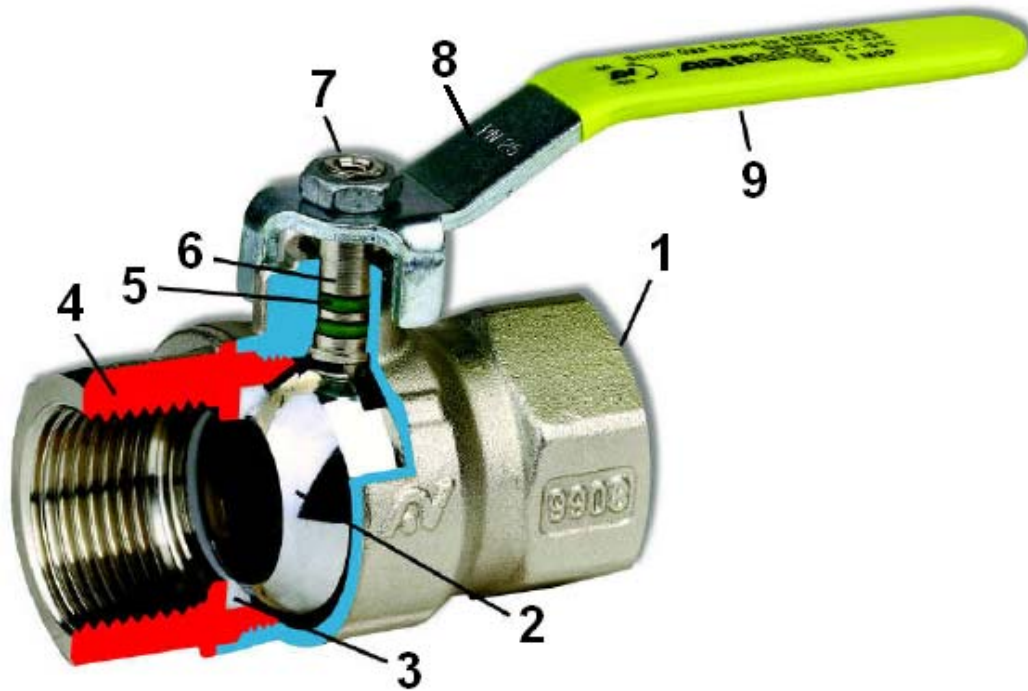

Item	Designation	Materials
1	Body	Brass CW 617 N according to EN 12165
2	Ball	Brass CW 617 N according to EN 12165 chromed
3	Seat	PTFE
4	Nipple	Brass CW 617 N according to EN 12165
5	O ring	FKM
6	Stem	Brass CW 614 N according to EN 12164
7	Handle nut	Steel
8	Handle	Steel
9	Handle cover	Plastic

BRASS BALL VALVE NF FOR GAS AIRGAS TYPE

SIZE (in mm) :

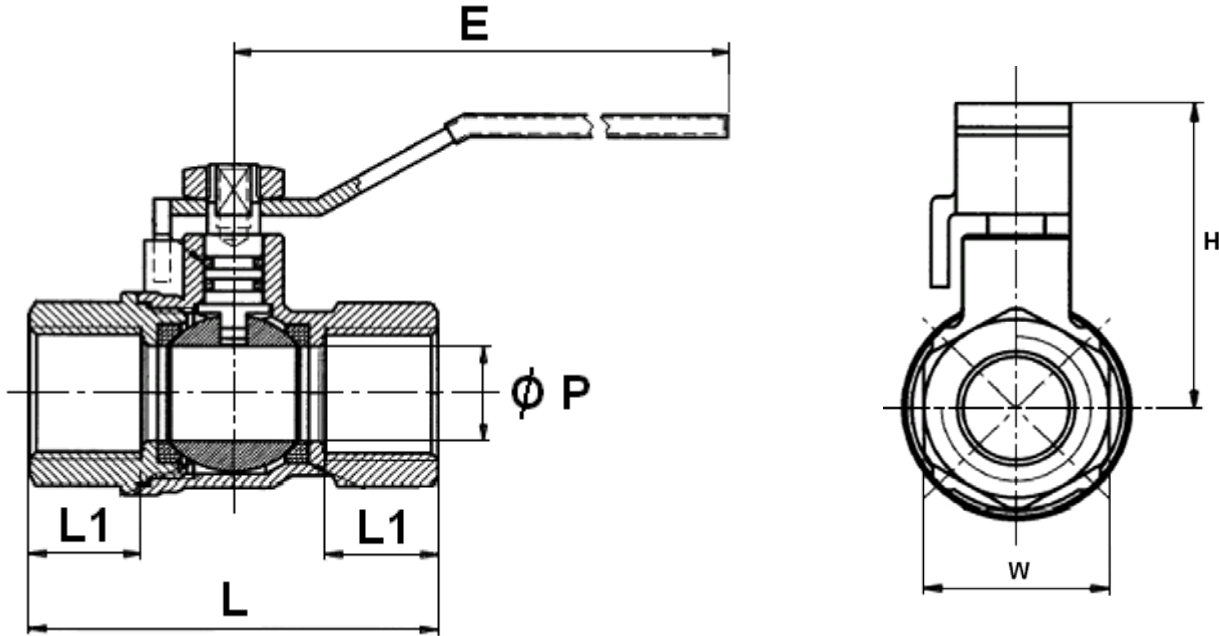

Ref.	DN	1/2"	3/4"	1"	1"1/4	1"1/2	2"
620	Ø P	15	20	25	32	40	47
	L	62	70	82	98	109	125
	L1	17	18.5	21	22	22	26
	E	90	110	110	115	115	150
	H	44	52.5	57	66	73.5	84
	W on flat	26	32	40	49	55	68
	Weight (Kg)	0.236	0.378	0.620	1.034	1.380	2.113

BRASS BALL VALVE NF FOR GAS AIRGAS TYPE

STANDARDS :

- Fabrication according to ISO 9001 : 2008
- DIRECTIVE 97/23/CE : Products excluded from directive (Article 1, § 3.6)
- GAS certificate **N° ROB 027-R3**
- BG Technologies agreement according to **EN 331 :1998**
- Designing according to **90/396/EEC** for gas families 1, 2 and 3
- Threaded female BSP cylindrical according to **UNI ISO 228/1**

ADVICE : Our opinion and our advice are not guaranteed and SFERACO shall not be liable for the consequences of damages. The customer must check the right choice of the products with the real service conditions.

USE :

Our liability can not be engaged for a non agreed using.
Especially for domestic using with a flexible gas pipe where a valve with automatic closing (ROAI) is mandatory.

BRASS BALL VALVE NF FOR GAS AIRGAS TYPE

INSTALLATION INSTRUCTIONS

GENERAL GUIDELINES :

- Ensure that the valves to be used are appropriate for the conditions of the installation (type of fluid, pressure and temperature).
- Be sure to have enough valves to be able to isolate the sections of piping as well as the appropriate equipment for maintenance and repair.
- Ensure that the valves to be installed are of correct strength to be able to support the capacity of their usage.
- **Installation of all circuits should ensure that their function can be automatically tested on a regular basis (at least two times a year).**

INSTALLATION INSTRUCTIONS :

- **Before installing the valves, clean and remove any objects from the pipes** (in particular bits of sealing and metal) which could obstruct and block the valves.
- **Ensure that both connecting pipes either side of the valve (upstream and downstream) are aligned (if they're not, the valves may not work correctly).**
- **Make sure that the two sections of the pipe (upstream and downstream) match, the valve unit will not absorb any gaps. Any distortions in the pipes may affect the tightness of the connection, the working of the valve and can even cause a rupture.** To be sure, place the kit in position to ensure the assembling will work.
- Before starting the fitting, ensure that the threads and tapping are clean.
- **If sections of piping do not have their final support in place, they should be temporarily fixed. This is to avoid unnecessary strain on the valve.**
- The theoretical lengths given by ISO/R7 for the tapping are typically longer than required, the length of the thread should be limited, and **check that the end of the tube does not press right up to the head of the thread.**
- Position the pipe clips on both sides of the valve.
- When screwing the valve, ensure that you only rotate on screwed side by the 6 ended side. Use an open ended spanner or an adjustable spanner and not a monkey wrench.
- **Never use a vice to tighten the fixings of the valve.**
- Do not over tighten the valve. Do not block with any extensions as it may cause a rupture or weakening of the casing.
- **In general, for all valves used in buildings and heating, do not tighten above a torque of 30 Nm.**

The advice and assembly instructions above do not conform to any guarantee.
The information is given in general. It states what must not and must be done.
It is provided to ensure the safety of the personnel and the reliability of the valves.
The instructions in bold must be followed.